

FM[®] 300

FM[®] 300 is a 350°F (177°C) curing modified epoxy film adhesive available with three different moisture-resistant polyester carriers, and is designed for bonding metal-to-metal and sandwich composite structures. To achieve ultimate environmental resistance in bonding aluminum details, use pre-cured BR[®] 127 primer with FM[®] 300 film adhesive.

Extensively used as a surface finished ply on composite materials' outside layers, FM[®] 300 film adhesive has unique properties which drastically reduce, and in some cases virtually eliminate, time-consuming sanding and filling operations.

FM[®] 300 film adhesive has high elongation and toughness with high ultimate shear strength. This makes it particularly suitable for redistributing the high shear stress concentrations of graphite epoxy-to-metal bonds, and allows it to accommodate the low inter-laminar shear strength of the composite. It is particularly good in fatigue resistance in these joints. In properly designed and processed joints, the tight-knit tricot carrier provides a degree of electrical isolation between metal and graphite composites to reduce galvanic corrosion.

Typical applications for FM[®] 300 include metal-to-metal bonding, composite-to-composite bonding, composite-to-metal bonding, and composite surfacing.

Features and Benefits

- Superior metal-to-metal peel strength, composite-to-composite bonding and composite-to-metal joints
- Extensively used as surfacing ply for composite materials
- Service temperature from -67°F to 300°F (-55°C to 149°C)
- Excellent moisture and corrosion resistance in high humidity environments with no significant reduction in mechanical properties
- Allows x-ray inspection of assemblies due to natural opacity of adhesive formulations
- Available in a wide range of film thicknesses tailored to specific applications
- Industry wide acceptance
- Compatible for co-cure or simultaneous autoclave with product FM[®] 61, FM[®] 96, and BR[®] 127

CHARACTERISTICS

Table 1 | Physical Properties

Shelf Life	12 months at or below 0°F (-18°C) from date of shipment for supported film 4 months at or below 40°F (4°C) from date of shipment for unsupported film
Shop Life	10 days at 90°F (32°C) 30 days at 75°F (24°C)
Volatiles ASTM D 3530	1.0% maximum 250°F (121°C)
Outgassing Properties ¹ (after complete cure) ASTM E 595	TWL - 0.92% CVCM - 0.07% WVR - 0.63 %

¹ Property reported for FM[®] 300K

Table 2 | Product Availability

Product Form	Nominal Weight ¹	Nominal Thickness	Color	Carrier	Characteristics
	psf (gsm)	in (mm)			
FM [®] 300	0.08 (391) 0.10 (488)	0.013 (0.33) 0.015 (0.38)	Blue Blue	Tight Knit	Enhanced bond line thickness control. Good blend of structural and handling properties
FM [®] 300K	0.05 (244) 0.08 (391)	0.008 (0.20) 0.013 (0.33)	Green Green	Wide Open Knit	Highest overall performance.
FM [®] 300M	0.03 (146) 0.08 (391)	0.005 (0.13) 0.013 (0.33)	Green Green	Random Mat	Provides the best bond line and flow control. Reduces tendency to trap air during lay-up.
FM [®] 300U	0.03 (146) 0.055 (269)	0.005 (0.13) 0.008 (0.20)	Green Green	Unsupported Film	Can be reticulated.

¹ Weight tolerance equals nominal weight ± 0.005 psf (± 25 gsm)

Table 3 | Physical Properties: BR[®] 127 Corrosion Inhibiting Primer

Shelf Life	12 months at or below 0°F (-18°C) from date of shipment
Shop Life	10 days at 90°F (32°C)
Color	Yellow
Solids	10% ± 1% sprayable
Density	7.3 lbs/gal (875 g/L)
Recommended Dry Primer Thickness	0.10 mil – 0.30 mil (.0025 mm - .0076 mm)
Recommended Cure	Airy dry 30 minutes in ambient conditions Cure 30 minutes at 250°F (121°C)

PROPERTIES

Table 4 | Mechanical Properties with Primer BR[®] 127

Property	Test Temp	FM 300 0.08 psf (391 gsm)	FM 300K 0.05 psf (244 gsm)	FM 300K 0.08 psf (391 gsm)	FM 300M 0.03 psf (146 gsm)	FM300M 0.08 psf (391 gsm)	Substrate
Lap Shear ASTM D 1002	°F (°C)	psi (MPa)					0.063 in (1.60 mm) 2024-T3 clad aluminum
	-67 (-55)	5080 (35.0)	–	5460 (37.7)	–	4930 (34.0)	
	75 (24)	5150 (35.5)	5340 (36.8)	5850 (40.3)	4330 (29.8)	5280 (36.4)	
	250 (121)	4000 (27.6)	3580(24.7)	4200 (28.9)	3360 (23.2)	4040 (27.9)	
	300 (149)	2910 (20.0)	2970 (20.4)	3160(21.8)	2310 (15.9)	2960 (20.4)	
Floating Roller Peel ASTM D 3167	°F (°C)	lb/in (kN/m)					0.025 in (0.63 mm) and 0.064 in (1.63 mm) 2024-T3 clad aluminum
	-67 (-55)	28 (4.9)	–	28 (4.9)	–	29 (5.1)	
	75 (24)	29 (5.1)	23 (4.0)	28 (4.9)	26 (4.6)	29 (5.1)	
	250 (121)	–	–	–	–	–	
	300 (149)	25 (4.4)	–	26 (4.6)	27 (4.7)	26 (4.6)	
Honeycomb Sandwich Peel ASTM D 1781	°F (°C)	in-lb/3 in (N/m)					0.020 in (0.51 mm) 2024-T3 clad aluminum skins; 0.002 (0.65 mm) NP 5052, 0.1875 in (4.76 mm) cell core
	-67 (-55)	–	25 (37)	40 (58)	–	–	
	75 (24)	–	22 (32)	45 (66)	11 (16)	–	
	250 (121)	–	–	–	–	–	
	300 (149)	–	22 (32)	28 (41)	–	–	
Flatwise Tensile ASTM C 297	°F (°C)	psi (MPa)					0.020 in (0.51 mm) 2024-T3 clad aluminum skins; 0.0025 (0.65 mm) NP 5052, 0.1875 in (4.76 mm) cell core
	-67 (-55)	1350 (9.3)	–	1080 (7.4)	–	1600 (11.0)	
	75 (24)	1010 (7.6)	–	1030 (7.1)	435 (3.0)	1390 (9.6)	
	250 (121)	–	–	–	–	–	
	300 (149)	345 (2.4)	340 (2.3)	470 (3.2)	125 (0.86)	513 (3.5)	

Table 5 | Humidity and Fluid Exposure with Primer BR[®] 127

Property	FM 300 0.08 psf (391 gsm)	FM 300K 0.08 psf (391 gsm)	FM 300M 0.08 psf (391 gsm)	Substrate
Lap Shear after 30 days at 120°F (49°C) 95 – 100% RH ¹ ASTM D 1002	psi (MPa)			0.063 in (1.60 mm) 2024-T3 clad aluminum
	5190 (35.8)	6230 (42.9)	5540 (38.2)	
Lap Shear after 7 days immersion in: JP-4 fuel Anti-icing fluid Hydraulic oil Hydrocarbon fluid	5030 (34.7)	6240 (43.0)	5550 (38.3)	0.063 in (1.60 mm) 2024-T3 clad aluminum
	4920 (33.9)	6280 (43.3)	5250 (36.2)	
	5100 (35.2)	6130 (42.3)	5350 (36.9)	
	5160 (35.6)	6095 (42.0)	5130 (35.3)	
	–	–	–	
Lap Shear after 200 hours in Skydrol ² hydraulic fluid at 150°F (66°C)	4940 (34.0)	6350 (43.8)	4860 (33.5)	0.063 in (1.60 mm) 2024-T3 clad aluminum

¹Tested at 75°F (24°C)

²A product of Solutia, Inc.

Table 6 | Effect of Humidity Exposure Prior to Bonding, FM[®] 300K 0.08 psf (391 gsm) with Primer BR[®] 127

Property	Test Temp	Control (no exposure)	15 Day Exposure at 54% RH	Substrate
Lap Shear ASTM D 1002	°F (°C)	psi (MPa)		0.063 in (1.60 mm) 2024-T3 clad aluminum
	75 (24)	4800 (33.1) 4700 (32.4) 4650 (32.1)	4900 (33.8) 4800 (33.1) 5200 (35.9)	
	300 (149)	3400 (23.5) 3300 (22.8)	2600 (17.9) 2900 (20.0)	
Floating Roller Peel ASTM D 3167	°F (°C)	lb/in (kN/m)		0.025 in (0.63 mm) and 0.063 in (1.60 mm) 2024-T3 clad aluminum
	75 (24)	28 (4.9) 29 (5.1)	28 (4.9) 29 (5.1)	
Honeycomb Sandwich Peel ASTM D 1781	°F (°C)	in-lb/3 in (N/m)		0.020 in (0.51 mm) 2024-T3 clad aluminum skins; 0.0025 (0.65 mm) NP 5052, 0.1875 in (4.76 mm) cell core
	75 (24)	75 (110) 68 (100)	75 (110) 69 (100)	

Cure Cycle: Standard 350°F (177°C) cure. See details below.

Table 7 | Heat Aging Studies at 300°F (150°C), FM[®] 300K 0.08 psf (391 gsm) with Primer BR[®] 127

Hours Exposure	Lap Shear tested at 75°F (24°C) ASTM D 1002	Lap Shear tested at 300°F (149°C) ASTM D 1002	Honeycomb Sandwich Peel tested at 75°F (24°C) ASTM D 1781	Flatwise Tensile tested at 75°F (24°C) ASTM C 297
	psi (MPa)		in-lb/3 in (Nm/m)	psi (MPa)
Control	6070 (41.8)	2980 (20.6)	64 (94)	1380 (9.5)
1440	4460 (30.8)	3720 (25.6)	35 (52)	–
2880	4700 (32.4)	3400 (23.5)	41 (60)	960 (6.6)
4320	4300 (29.7)	3430 (23.7)	26 (39)	1000 (6.9)
5040	3910 (27.0)	3530 (24.4)	23 (34)	990 (6.8)
5760	3210 (22.1)	3450 (23.8)	20 (30)	950 (6.6)
7200	3580 (24.7)	3450 (23.8)	20 (30)	–
7920	3270 (22.6)	2960 (20.4)	17 (25)	780 (5.4)

Substrate: Lap Shear: 0.063 in. (1.63 mm) 2024-T3 clad
 Honeycomb Skins: 0.020 in (0.51 mm) 2024-T3 clad
 Honeycomb Core: 0.1875 in (4.76 mm) 0.0025 (0.65 mm) NP 5052

Cure Cycle: Standard 350°F (177°C) cure. See details below.

KGR STRESS STRAIN DATA

The heart of Solvay Engineered Materials new technology for structural adhesives is the KGR-1 extensometer. This instrument provides the basic, definitive property of a structural adhesive – its shear stiffness. KGR-1 records the entire stress strain curve for the adhesive in environments reproducible in the laboratory.

This technology benefits both the designer and the adhesive formulator. The designer and stress analyst use this technology to predict the service performance of the adhesive bond, including strength, creep and fatigue in environments reproducible in the laboratory.

Until Solvay Engineered Materials developed the KGR-1, test methods to obtain shear stiffness were either inaccurate or too costly to allow sufficient data for statistical confidence. A measure of the difficulty in obtaining this stiffness is that movements of one quarter of a micron (0.00001 inches) must be detected with clarity and reliability. KGR-1 does this over a temperature range of -67°F (-55°C) to 500°F (260°C) in hostile environments reproducible in the laboratory.

The economy of operation of KGR-1 makes stiffness data affordable to the designer. This economy allows statistical confidence necessary for practical analysis. In addition to stiffness, KGR-1 provides the shear stress strain relationship over the entire non-linear range up to and including ultimate failure.

It has been established that fatigue life and residual static strength are dependent on strain at ultimate stress. The larger the strain, the longer the fatigue life and the higher the residual static strength (the strength after the joint has seen the required fatigue loads). This data defines limits for creep and fatigue conditions. It is possible to perform proper stress analysis of bonded aircraft primary structure. Accurate predictions are now possible for the bond performance over the life of the aircraft.

Apart from its value to the designer, KGR-1 technology is invaluable to the formulator of structural adhesives. Stress strain properties beyond the linear range define the adhesive’s performance in fatigue and toughness.

If you are interested in acquiring a KGR-1 extensometer for help in your own work, please contact a Solvay Engineered Materials representative.

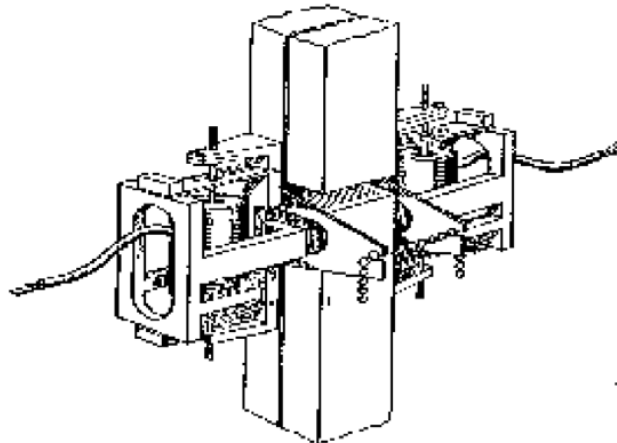
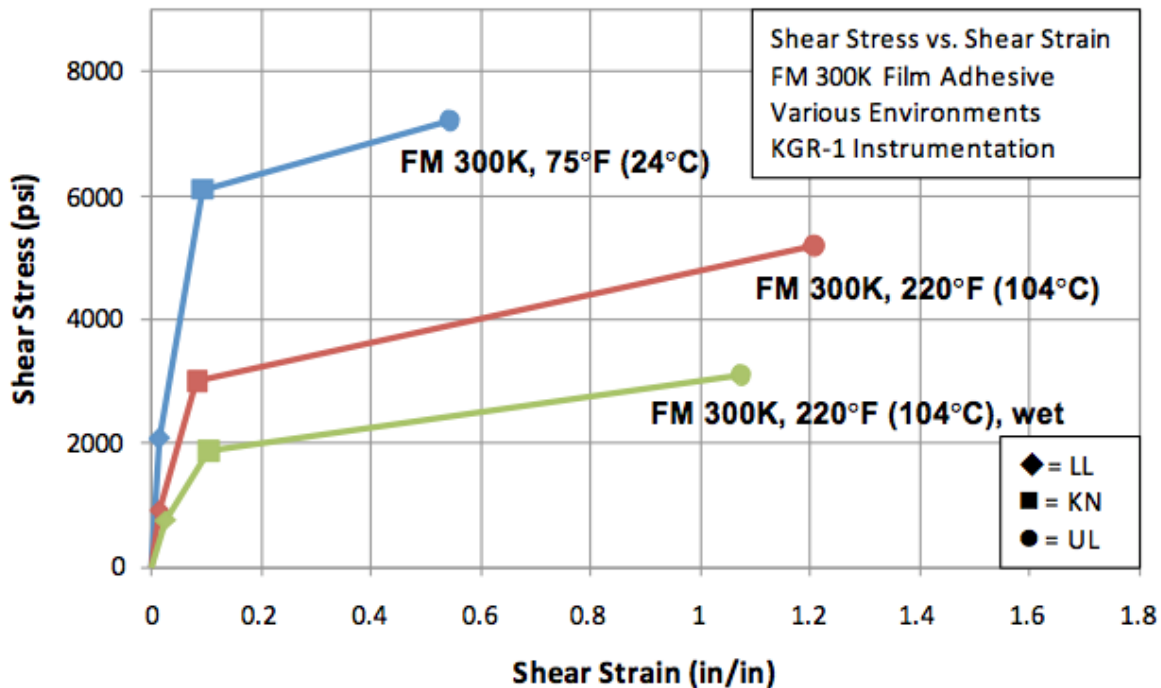

Table 8 | KGR-1 Stress Strain Data for FM[®] 300K Adhesive Film, 0.06 psf (293 gsm) with BR[®] 127 Primer, ASTM D 5656

[f = Shear Stress, psi (MPa), Σ = Shear Strain, in/in, G = Shear Modulus, psi (Mpa)]

Test Temp °F (°C)	Linear Limit (LL)			Knee (KN)		Ultimate Failure (UL)	
	f	Σ	G	f	Σ	f	Σ
75 (24)	2060 (14.2)	0.0156	131,500 (907.5)	6100 (42.1)	0.0932	7210 (49.8)	0.5446
220 (104)	916 (6.32)	0.0150	64,700 (446.2)	3000 (20.8)	0.0835	5190 (35.8)	1.2073
220 (104) ¹	745 (5.14)	0.0273	27,500 (189.8)	1880 (13.0)	0.1047	3100 (21.4)	1.0744

¹Postbond exposure to 100% RH at 140°F (60°C) until saturated



PROCESSING

Recommended Cure Cycle

Autoclave Cure Cycle Apply full vacuum, 24 in Hg (0.081 MPa) minimum.
 Apply 40 psi (0.28 MPa) pressure, vent vacuum at 20 psi (0.14 MPa).
 Heat from 75°F (24°C) to 350°F (177°C) at 2°F - 5°F (1°C - 3°C)/minute.
 Hold at 350°F (177°C) for 60 minutes.
 Cool under pressure below 140°F (60°C) at 2°F - 5°F (1°C - 3°C)/minute.

FM[®] 300 film adhesive may also be bonded at pressures ranging from 15 psi – 100 psi (0.10 MPa – 0.69 MPa) depending upon the application. For press, pressure diaphragm or vacuum bag curing use the following cure cycle:

Alternative Cure Cycle Heat from 75°F (24°C) to 350°F (177°C) in 60 minutes.
 Hold at 350°F (177°C) for 60 minutes.

Surface Preparation

Aluminum Skins

A clean, dry, grease-free surface is required for bonding. FM[®] 300 can be used with standard cleaning techniques involving a four step procedure of solvent degreasing, alkaline cleaning, chemical deoxidizing (etching), and phosphoric acid anodizing*. General guidance for etching and phosphoric acid anodizing can be found in ASTM 2651 and ASTM 3433, respectively. Best results for aluminum feature priming after appropriate surface preparation, with BR[®] 6747-1, BR[®] 6747-1 NC or BR[®] 127 primer.

*Boeing patent 4,085,012. April 1978. Phosphoric acid anodizing is now being used by a large number of aircraft manufacturers due to the improved surface bond durability it provides.

Primer Application

Although not mandatory, BR[®] 127 corrosion inhibiting primer is recommended for use with FM[®] 300 adhesive in the bonding of aluminum details. BR[®] 127 primer offers superior durability and resistance to hostile environments within the bond line and also may be used as a protective coating outside the bonded areas. Apply BR[®] 127 as follows:

1. Allow BR[®] 127 material to warm to room temperature, 75°F (24°C), prior to opening container
2. Thoroughly mix before application and agitate during application
3. Spray or brush coat to a dry primer thickness of 0.0001 inch (0.0025 mm) nominal with a 0.0003 inch (0.0076 mm) maximum thickness
4. Air dry 30 minutes minimum prior to using
5. Oven dry 30 minutes at 250°F ± 10°F (121°C ± 6°C)

LAY-UP PROCEDURE

1. When FM[®] 300 is removed from refrigerator storage, the adhesive must be allowed to reach room temperature [75°F (24°C)] before the roll is unpackaged. Note that the adhesive film is sandwiched between release paper and polyliner.
2. Remove either of the interliners and place the adhesive against the surface to be bonded. Care should be taken to prevent air entrapment between the film adhesive and substrate, especially in large area bonds.
3. If additional tack is desired, the adhesive may be heated to as high as 140°F (60°C) for up to 30 minutes without altering the adhesive properties. Before heat tacking, ensure the film is properly positioned, otherwise removal will be difficult.
4. Complete the assembly after removing the other interliner.

Recommended Consumables

Table 7 below provides a list of Solvay's consumable processing materials recommended for use with FM[®] 300.

Table 7 | Solvay's Processing Materials

Sealant Tape	SM5142BY, SM 5127, SM5126
Release Film	A6200, A5000
Release Fabric	200 TFP, 200 TFNP
Breather/Bleeder Fabric	RC3000-10, A3000-4
Peel Ply	60001, 60002, 51789
Bagging Film	HS 8171, SV3000
Adhesive Tape	Flashtape 1, Flashtape 2

Recommended processing materials listed above can be purchased through Solvay. Technical Data Sheets (TDS) and additional information are available at www.solvay.com

HEALTH & SAFETY

Please refer to the product SDS for safe handling, personal protective equipment recommendations and disposal considerations.

DISCLAIMER: The data and information provided in this document have been obtained from carefully controlled samples and are considered to be representative of the product described. Solvay does not express or imply any guarantee or warranty of any kind including, but not limited to, the accuracy, the completeness or the relevance of the data and information set out herein. Because the properties of this product can be significantly affected by the fabrication and testing techniques employed, and since Solvay does not control the conditions under which its products are tested and used, Solvay cannot guarantee the properties provided will be obtained with other processes and equipment. No guarantee or warranty is provided if the product is adapted for a specific use or purpose. Solvay declines any liability with respect to the use made by any third party of the data and information contained herein. Solvay has the right to change any data or information when deemed appropriate. All trademarks are the property of their respective owners. ©2018, Solvay. All rights reserved.

Solvay

Composite Materials HQ
4500 McGinnis Ferry Rd
Alpharetta, GA 30005-3914 USA

TDS FM[®] 300_2018_06_14



SOLVAY

asking more from chemistry[®]